

DolorClast® High Power Laser (FT-245) - Replacing the lens

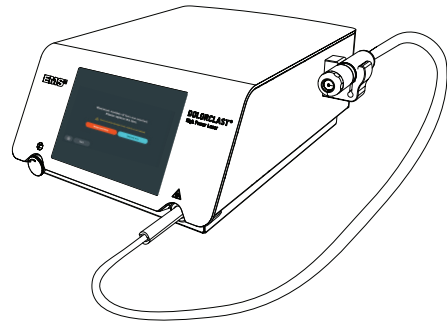

01

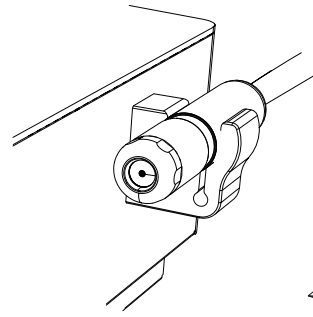

02

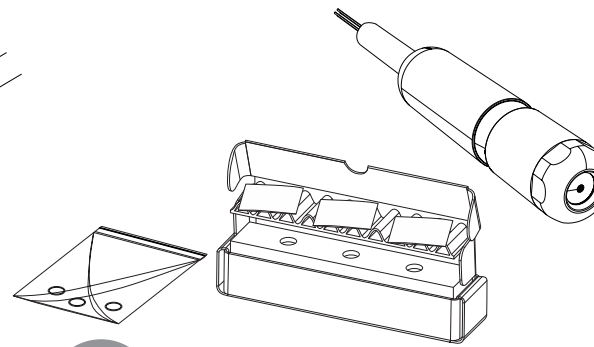

03

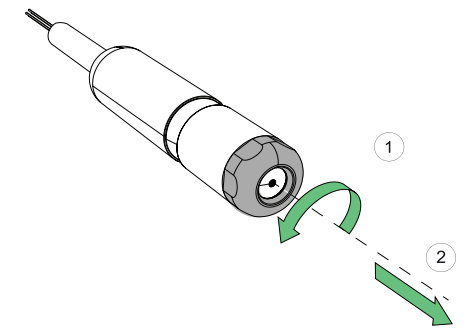

04

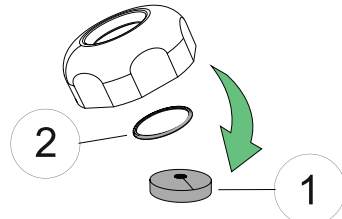

05

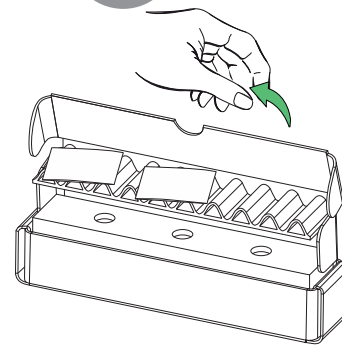

06

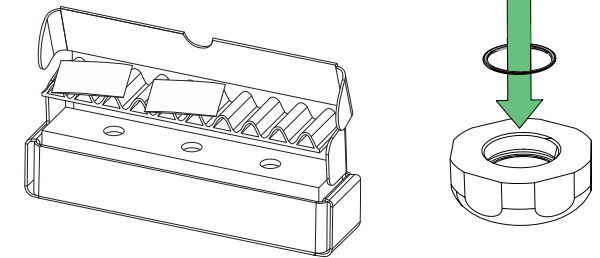

07

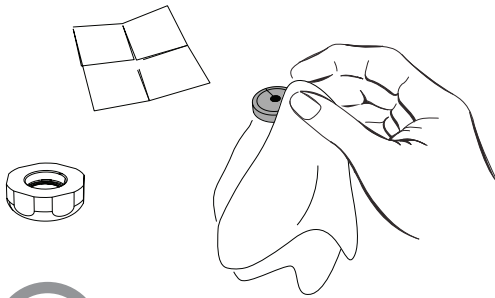

08

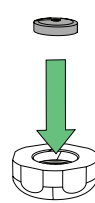

09

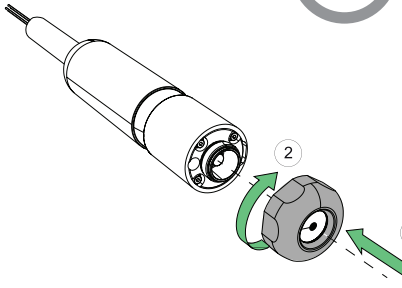
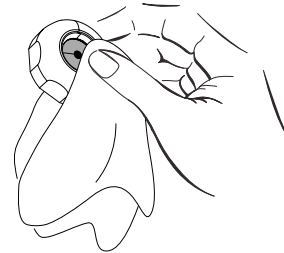

10

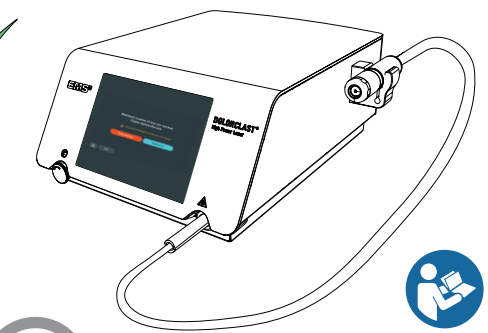

11

FR - Consulter le mode d'emploi pour obtenir des instructions complètes
DE - Weitere Informationen zum Betrieb finden Sie in der Bedienungsanleitung
IT - Per le istruzioni complete sul funzionamento, consultare il manuale delle istruzioni

ES - Consulte el manual de instrucciones para ver las instrucciones completas
RU - Все рабочие инструкции приведены в руководстве по эксплуатации
TR - Çalıştırma talimatlarının tamamı için, kullanım kılavuzuna bak

NL - Raadpleeg de gebruikshandleiding voor de volledige bedieningsinstructies
EL - Για τις πλήρεις οδηγίες λειτουργίας ανατρέξτε στο εγχειρίδιο χρήσης
HR - Pogledajte priručnik s uputama kako biste pročitali cjelovite upute za rukovanje
CZ - Úplněné pokyny k použití naleznete k návodu k obsluze

ET - Kõigi kasutusjuhiste nägemiseks lugege käsutusjuhendit
LV - Pilnas norādes par ekspluatāciju skatiet lietošanas instrukcijā
LT - Pilnas valdymo instrukcijas rasite naudojimo vadove
SK - Pozrite si príručku, v ktorej nájdete úplné pokyny na používanie

SL - Več informacij o uporabi najdete v navodilih za uporabo
HU - A teljes üzemeltetési utasításokért lásd a használati útmutatót
FI - Katso täydelliset ohjeet käyttöoppaasta
PL - Wszystkie zalecenia dotyczące obsługi znajdują się w instrukcji obsługi

RO - Pentru instrucțiunile de utilizare complete, consultați manualul de instrucțiuni
PT - Consulte o manual de instruções para obter instruções de utilização completas
SE - Se användarhandboken för fullständig bruksanvisning

DK - Se brugsanvisningen for den fulde betjeningsvejledning
NO - Se bruksanvisningen for fullstendige driftsinstruksjoner
CN - 关于完整操作说明, 请参阅说明书
JP - 完全な操作手順については、取扱説明書を参照してください

UA - Детальні інструкції з експлуатації шукайте в посібнику з експлуатації



Refer to the instruction manual for full operating instructions

EMS

DolorClast® High Power Laser (FT-245)



HEADQUARTERS

CH



NYON, SWITZERLAND
ELECTRO MEDICAL SYSTEMS SA
Chemin de la Vuarpillière 31
CH - 1260 Nyon
www.ems-dental.com/en/contact
T. +41 22 99 44 700
F. +41 22 99 44 701



WORLDWIDE EMS AFFILIATES

DE

MUNICH, GERMANY
EMS ELECTRO MEDICAL SYSTEMS GMBH
Stahlgruberring 12
DE - 81829 München
T +49 89 42 71 61 0
F +49 89 42 71 61 60
E-mail: info@ems-ch.de

FR

FONCINE, FRANCE
EMS ELECTRO MEDICAL SYSTEMS FRANCE SARL
32, route de Pontarlier
FR - 39460 Foncine-le-Haut
T +33 3 84 51 90 01
F +33 3 84 51 94 00
E-mail: info@ems-france.fr

ES

MADRID, SPAIN
EMS ELECTRO MEDICAL SYSTEMS ESPAÑA SLU
C/ Tomás Bretón, 50-52 2ª planta
ES - 28045 Madrid
T +34 91 528 99 89
E-mail: info@ems-espana.com

IT

MILANO, ITALY
EMS ITALIA S.R.L
Via Carlo Pisacane 7 B
IT - 20016 Pero (MI)
T +39 02 3453 8111
F +39 02 3453 2778
E-mail: dental@ems-italia.it

PL

KATOWICE, POLAND
EMS POLAND SP. Z O.O.
Al. Różdzieńskiego 188H
PL - 40-203 Katowice
T +48 32 4937060
E-mail: info@ems-poland.com

SE

STOCKHOLM, SWEDEN
EMS NORDIC AB
Hammarby Fabriksväg 61
SE - 120 30 Stockholm
T +46 8 899 102
E-mail: info@ems-nordic.se

JO

AMMAN, JORDAN
E.M.S ELECTRO MEDICAL SYSTEMS JORDAN
No.2 - second floor, 195 Arar (Wadi Saqra) str.
JO - Amman

US

DALLAS, USA
EMS Corporation
11886 Greenville Avenue, Ste 120
US - Dallas, Texas 75243
T +001 972 690 8382
F +001 972 690 8981
E-mail: info@ems-na.com

AU

SYDNEY, AUSTRALIA
E.M.S. ELECTRO MEDICAL SYSTEMS OCEANIA
Unit 1, Building 4 – Sydney Corporate Park
160 Bourke Road
AU - Alexandria, NSW 2015
T +61 405 095 867
E-mail: info@ems-oceania.com

CN

SHANGHAI, CHINA
医迈斯电子医疗系统贸易(上海)有限公司
E.M.S. ELECTRO MEDICAL SYSTEMS TRADING (SHANGHAI) CO., LTD.
24A, Jin Sui Mansion,
N°379 Pudong Nan Rd.
CN - Shanghai 200120
T +86 21 3363 2323
E-mail: emschina@ems-ch.com

JP

TOKYO, JAPAN
E.M.S. JAPAN BRANCH OFFICE
Eminent Ningyoucho Bld 6F.,
9-18, Kobuna-cho, Nihombashi,
JP - Chuo-ku, Tokyo, 103-0024
T +81 (0) 3-6810-9351
F +81 (0) 3-6810-9352
E-mail: emsjapan@ems-ch.com

UK

CAMBRIDGESHIRE, UNITED KINGDOM
EMS UK LTD SUITE 2
Xenus House, Sandpiper Court
Phoenix Park - Eaton Socon
UK - St Neots, Cambridgeshire
PE19 8EP
T +44 01480 587260
E-mail: info@ems-unitedkingdom.com

KR

SEOUL, SOUTH KOREA
EMS ELECTRO MEDICAL SYSTEMS KOREA LTD.
13, Beobwon-ro 8-gil, Songpa-gu
T. +82 70 7807 2875
E-mail: emskorea@ems-ch.com